



Installation Sheet (Wiegand Interface)

SR-2400 Low-Frequency Card Reader

These instructions are for AWID's SR-2400 Reader, using compatible proximity credentials from AWID.

Parts List

- (a) 1 Installation Sheet for SR-2400
- (b) 1 Model SR-2400 Reader
- (c) 2 #6-32 × 1" thread-cutting screw, type 23
- (d) 3 Screw-hole plug (1 spare)

Preparation

Reader Location: Select the reader's mounting location. The SR-2400 Reader may be screwed to a 1-3/4 inch door frame, or to a wall or other surface. On a metal surface, read range is reduced about 20%. The SR-2400 may be installed indoors or outdoors. The diagram for screw and cable holes is on page 2.

DC Power Supply: DC power for this reader is usually supplied from the +DC and Ground terminals of the Wiegand reader port on the system's panel. If this is not possible, use a separate power supply. Power may be shared with other readers if the supply has sufficient current capacity. The power supply should be close to +12 volts DC (as low as +5 volts is OK), 750 milliamperes capacity, linear-rated, regulated DC output.

Cable to Controller and Power Supply: 4 to 6 conductors from the reader to the system (2 wires for DC power, 2 wires for Wiegand data, and 1 or 2 wires for external LED and Beeper/Alarm, if used). 22-gauge stranded wires. Overall 100% shield for both power and data. 500 feet maximum length.

- If the DC power supply is separated from the panel's reader port, the reader's **black** wire must be connected to *both* the DC power supply's Negative terminal and the panel reader port's Ground terminal.
- If the separate DC power supply is close to the reader, run two 22-gauge cables – 2 wires for DC power, and 3 to 5 wires for Wiegand data (including Ground) and for the external control lines, if used. *Both* cables must be overall-shielded and earth-grounded (at the end far from the reader).
- Conduit: If cables are pulled through metal conduit, the conduit should be earth-grounded (like the cables).

Installation

1. **Connector** – Cut off the 10-pin in-line connector from the end of the reader's cable. Discard the connector.
2. **Wire Connections** – Connect the reader's wires to the cable(s) for power and data.
 - a. First, connect **black** to the panel port's Ground terminal, and, if separate, to the power supply Negative.
 - b. Connect **green** to the Data-0 terminal. Connect **white** to the Data-1 terminal.
 - c. Connect the **gray** drain wire to the shield of the connecting cable.
If power and data are in separate cables, connect all three drains/shields together near the reader.
 - d. If the LED and/or Beeper/Alarm features are used, connect the **brown** and/or **yellow** wires.
 - e. At the end of the cable(s) near the panel (and near the power supply, if separate), connect the **shield** to a verified earth-ground.
 - f. Last, connect **red** to the DC Positive terminal.

(continued)

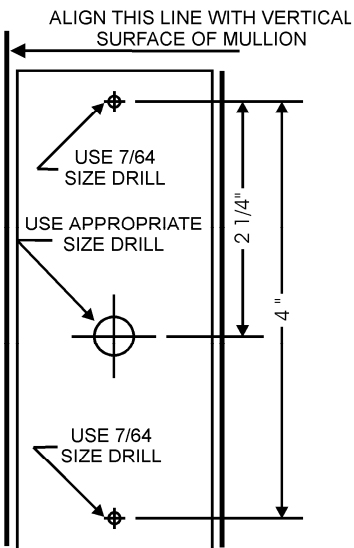

LF Card Reader

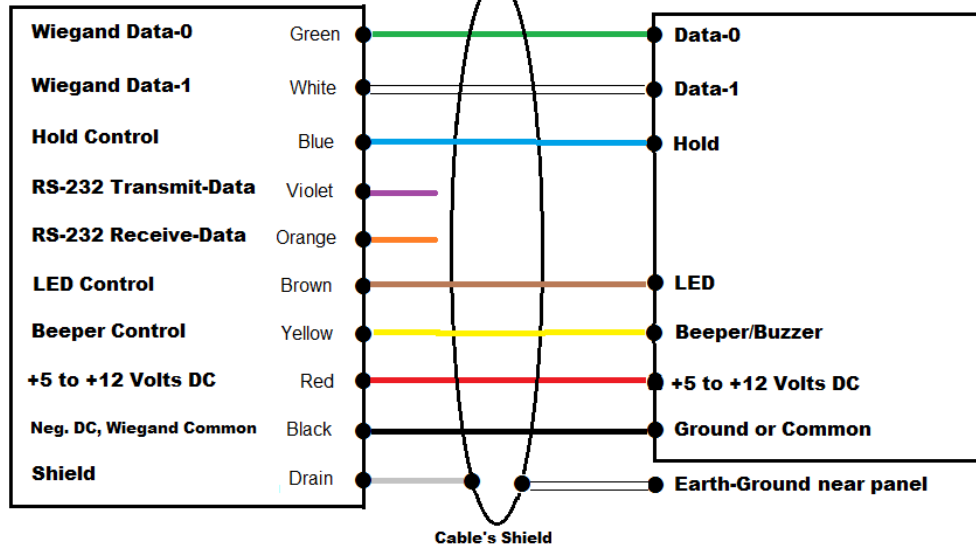

Note: The SR-2400 reader has no Hold control or RS-2232 interface. Do not use the **blue**, **violet** and **orange** wires.

- Reader Mounting** – Feed the reader’s cable through the cable opening in the door frame or wall. Fasten the reader to the frame or wall, with screws through the holes from the front of the reader. Use the supplied screws or other fasteners for mounting. After final testing, push the screw-hole plugs over the screw heads.
- Reader Test** – When power is applied to the SR-2400, the LED initializes to steady-red for standby, and the beeper sounds. With every presentation of an AWID LF proximity card to the reader, the LED changes color momentarily, and the beeper sounds briefly. Read range with a compatible card is up to 5-1/2 inches.
- System Test** – Wire the reader to the system’s controller. Program the code for the AWID proximity card or tag into the host system, with full priority, all doors groups, and all time zones. Present the card or tag to the reader. Observe door unlock or gate opening, indicating “Access Granted” by the system.

Technical Support • Call 408-825-1100, option 1. E-mail Support@awid.com.

SR-2400 has been evaluated to the following Access Control Performance Levels for UL standard 294:

- Destructive Attack – Level I (No Attack).
- Line Security – Level I (No Line Security).
- Endurance – Level IV (100,000 cycles).
- Standby Power – Level I (No Standby Power).

