

2

1

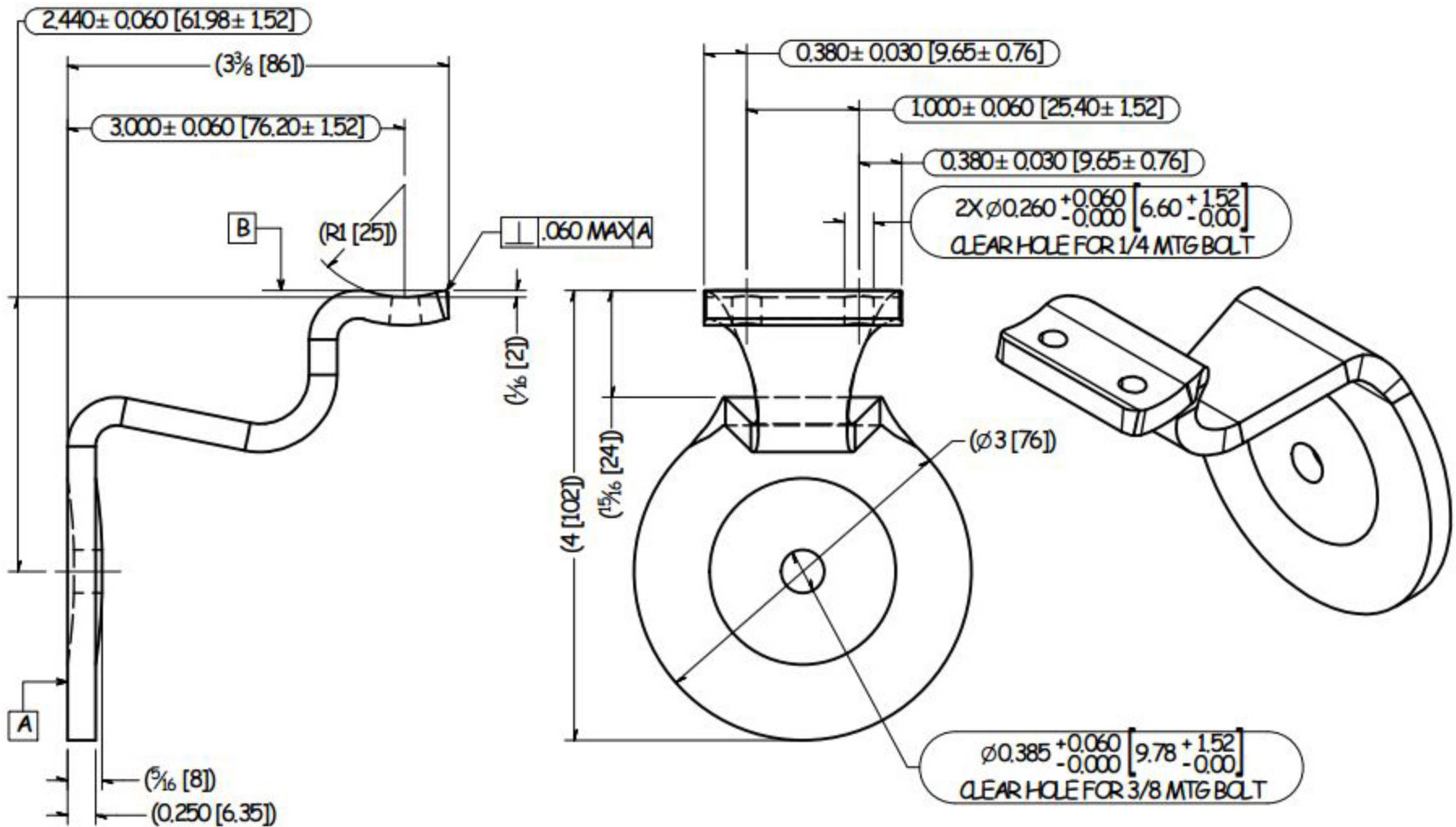

NOTES:

1. DIMENSIONS SHOWN AS INCHES [MILLIMETERS].
2. DIMENSIONS WITH (XXX) DENOTE AS REFERENCE.
3. ENCIRCLED DIMENSIONS DENOTE AS CRITICAL DIMENSIONS.
4. BURRS 0.015 MAX. [0.381]

TOLERANCE	CUT LENGTH:	FINISH:	DESCRIPTION:
FRACTION: X/XX..... = ± 1/16" over 4ft.		MILL	BRACKET ST 1/4 3.00 1HOLE ROUND STAMPED
DECIMAL: X.XX..... = ± .030 X.XXX..... = ± .010	DEVELOPED LENGTH:	WEIGHT:	MATERIAL: C7200 MATERIAL DESC: COIL STEEL 0.250 x 7.625 HRPO CQ ASTM A1011
UNLESS OTHERWISE NOTED	TOOL NUMBER: TL8875	SIZE: A	DATE: 1/13/2010 DRAWN BY: WWW.TSDISTRIBUTORS.COM
			ITEM NUMBER: 1938R SHEET: 1 OF 1 DRAWING NUMBER: 1938R REV: 1

2

1