

ENFORCER®

DP-234Q (NTSC)
DP-734Q (PAL)

Hands-Free Video Door Phone Manual



Screen image simulated.



- Camera has four LEDs for nighttime operation
- Remotely and securely talk to visitors and unlock doors, gates, etc. from the monitor
- Easily connect a secondary monitor*

- Simple 2-wire connection
- Built-in microphone
- Adjustable color tone, brightness, speaker and ringer volume
- Camera and monitor turn off when not in use

*Second monitor sold separately.

SECO-LARM® SLI

FC CE RoHS

Note: Products with model numbers that end with "Q" or that have a round green "Q" sticker are RoHS compliant.

Table of Contents:

Specifications	2	Installation – Secondary Monitor.....	5
Parts List	2	Installation – Camera.....	5
Overview	3	Operating Instructions.....	6
Installation Notes.....	4	Wiring Diagrams	7
Installation – Primary Monitor.....	4	Troubleshooting	8

Specifications:

Camera	
Type	Color camera
CCD	1/3" Sony Super HAD II
DSP	Enhanced Effio-E
Resolution	700 TV lines
Lens	4.5mm
Relay output	1A@12VDC max. dry contact
Weight	11-oz (312g)
Current draw	180mA
Dimensions	2 ³ / ₁₆ "x5 ⁵ / ₁₆ "x1 ⁹ / ₁₆ " (55x135x39 mm) with sunshield

Monitor	
Display	TFT
Operating voltage	17VDC
Relock delay	3 seconds
Weight	1-lb, 1-oz (482g)
Current draw	Active: 225mA
	Standby: 40mA
Dimensions	9 ⁵ / ₈ "x6 ⁵ / ₁₆ "x1 ¹ / ₁₆ " (245x160x18 mm)

Note: The distance between the camera and the farthest monitor should not exceed 264ft (75m).

Parts List:

DP-234Q / DP-734Q

Complete Kit



- 1x Hands-free monitor
- 1x Monitor bracket
- 1x AC Power adapter
- 1x Camera
- 1x Camera bracket
- 8x Screws
- 8x Screw anchors
- 1x Camera screw
- 2x Wire connectors (2-Wire)

Screen image simulated.

Also Available:

DP-234-MQ

Hands-Free
Secondary Monitor



- 1x Hands-free monitor
- 1x Monitor bracket
- 1x AC Power adapter
- 4x Screws
- 4x Screw anchors
- 2x Wire connectors (2-wire)

Compatible with DP-234Q / DP-734Q
and DP-222Q

Screen image simulated.

DP-222-MQ

Handset
Secondary Monitor



- 1x Handset monitor
- 1x Monitor bracket
- 1x AC Power adapter
- 4x Screws
- 4x Screw anchors
- 2x Wire connectors (2-wire)

Compatible with DP-234Q / DP-734Q
and DP-222Q

Screen image simulated.

Overview:

Primary Monitor

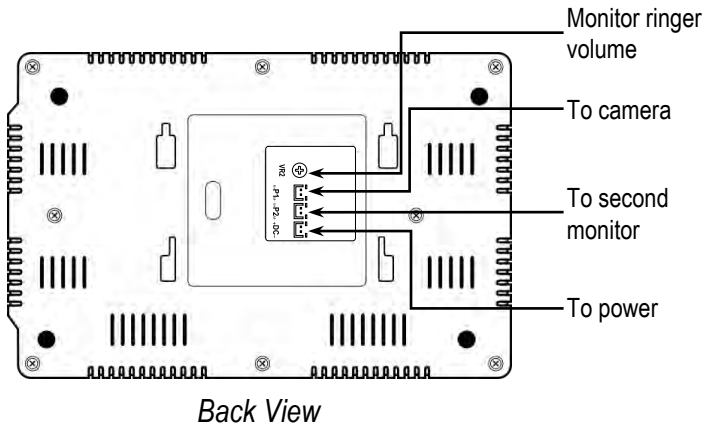
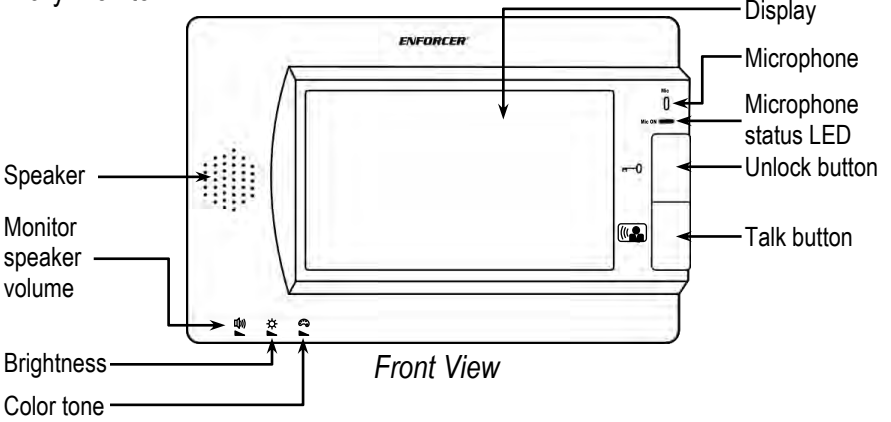

Camera Unit

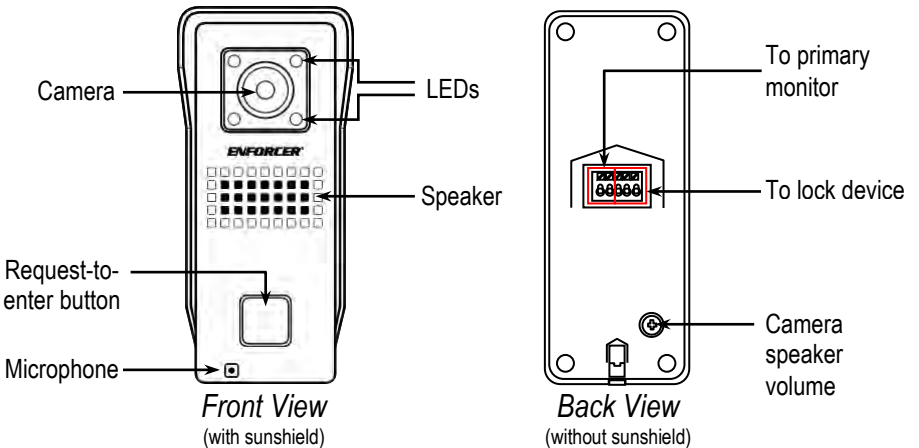

Installation Notes:

1. Unpack the video door phone and note the included parts.
2. Read this manual thoroughly. A clear understanding of the manual will make installation and operation much easier.
3. Find a good location to mount the monitor and camera. Make sure there is enough 21AWG 2-conductor wire to wire both units correctly.
4. Use only untwisted-pair wire; twisted-pair wire may cause interference.
5. Avoid mounting the camera or monitor near sources of strong electromagnetic signals or other electronic devices as they may cause interference.
6. Avoid mounting the camera in direct sunlight or exposing the camera to strong vibrations or direct rain or other moisture, which could result in damage to the camera.
7. The monitor contains no user-serviceable parts. Opening it may damage sensitive components and will void the warranty.

Installation – Primary Monitor:

1. The monitor must be positioned so that the image can be seen clearly and the user can operate the monitor's functions.
2. Use the mounting bracket as a template to pencil in where to drill the holes for the mounting bracket screws.
3. Drill the mounting bracket holes as needed. Drill a hole large enough to fit a min. 21AWG 2-conductor wire, which will run through the wall from the monitor to the camera.
4. Using four of the included screws and four of the included screw anchors, attach the monitor bracket to the wall, running the cable through the large hole in the mounting bracket.
5. Run wires from the first two terminals on the left of the camera (+ and -) to the monitor's "P1" plug making sure to observe polarity.

NOTE: If using only one monitor, the "P2" plug on the back of the monitor will not be used.

6. Connect the AC power adapter's wires into the "DC" plug on the back of the monitor, making sure to observe polarity.
7. Plug the AC power adapter into a 120VAC socket.
8. Test the monitor and camera unit by pressing the request-to-enter button on the camera. The image in front of the camera should be displayed clearly.

Monitor mounting bracket

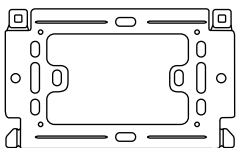

Connection points

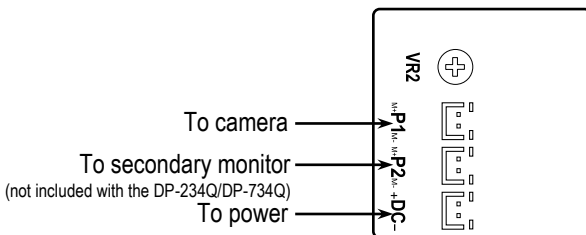

Installation – Secondary Monitor:

If using a secondary monitor:

1. Install the second monitor in the same way as the primary monitor (see page 4).
2. **DP-234-MQ or DP-222-MQ:** Run wire from the primary monitor's "P2" plug to the secondary monitor's "P1" plug, making sure to observe polarity.

Connecting to DP-234-MQ or DP-222-MQ
(not included)

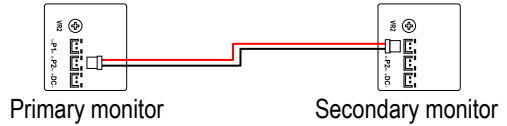

Installation – Camera:

1. Position the camera so the area to be monitored is easily visible, typically 5ft (150cm) above the ground. Do not position the camera in direct sunlight, or where it will be exposed directly to rain or snow.

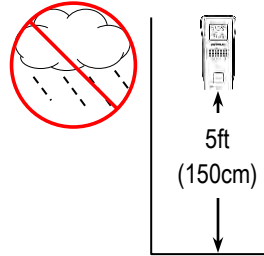

2. Cut a hole large enough to run the min. 21AWG 2-conductor wire through the wall to where the monitor unit is to be mounted. If using a locking device, the wires used to control the device must also be run through this hole.

3. Run the 2-conductor wire from the camera location to where the primary monitor is mounted.

Note: The distance between the camera and farthest monitor should not exceed 246ft (75m).

4. Using two of the included screws and two of the included screw anchors, attach the camera mounting bracket to the wall.
5. Run wires from the first two terminals on the left of the camera (+ and -) to the monitor's "P1" plug making sure to observe polarity.

Camera Mounting Bracket

Use these holes to secure the bracket to the wall.

Camera slots and screws into this tab.

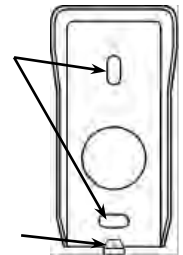

6. If the color video door phone will be used to operate an electronic door strike or electromagnetic lock, connect the wires coming from the strike or lock to the relay connections on the back of the camera. See the diagrams on page 7.

Connection points and speaker adjustment

7. To adjust the camera volume, turn the potentiometer on the back of the camera clockwise or counterclockwise.

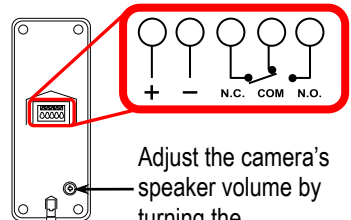

Adjust the camera's speaker volume by turning the potentiometer on the back of the unit.

8. Push the two tabs on top of the bracket into the top of the camera. Make sure that no wires are preventing the camera from seating properly in the bracket.

9. Secure the camera to the mounting bracket with the included camera screw.

Operating Instructions:

1. When the request-to-enter button on the camera is pressed, the monitor will ring twice. After ringing, any connected monitors will switch on.

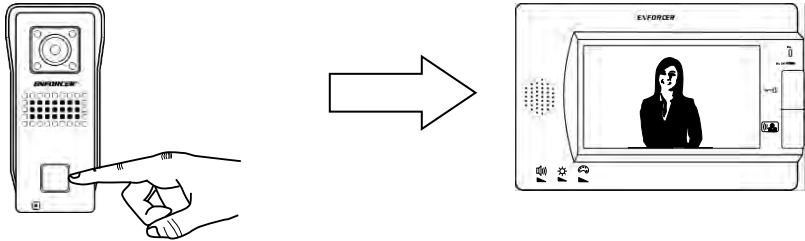

2. Press the talk button  on the monitor to hear audio and to talk through the camera.

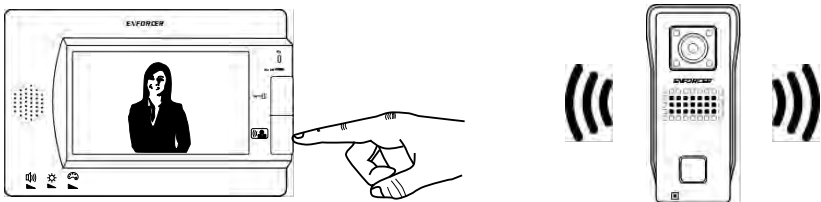

3. If the video door phone is connected to an electric door strike or other locking device, press the door unlock button to allow entrance. See the wiring diagram on page 7 for more details.
Note: The lock will only remain unlocked for three seconds after which the camera and monitor will turn off.

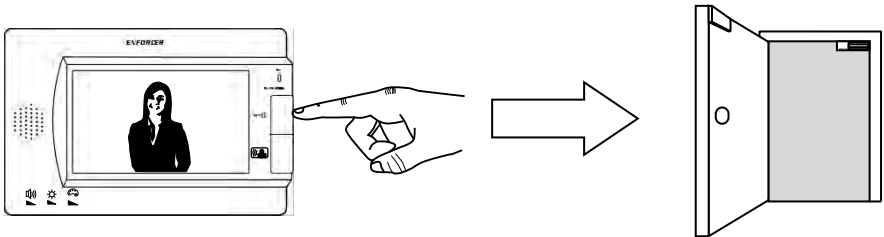

4. To see and hear what is going on at the entrance, press the talk button on the monitor. The camera and monitor will automatically switch on. When finished, simply press the talk button again and the camera will switch off. If the talk button is not pressed again, the monitor and camera will switch off after two minutes.

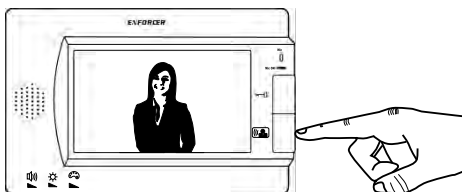

Wiring Diagrams:

Wiring a Secondary Monitor and Electric Door Strike

NOTE: The distance between the camera and the farthest monitor should not exceed 264ft (75m).

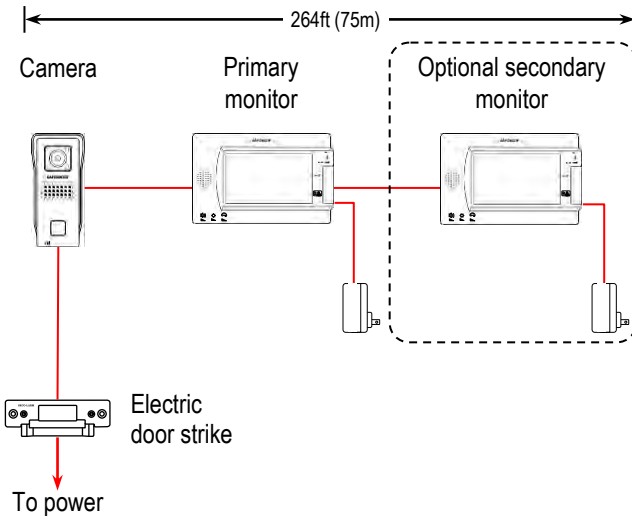

Connection Points (Shown with Fail-Secure Door Strike)

NOTE: Observe polarity

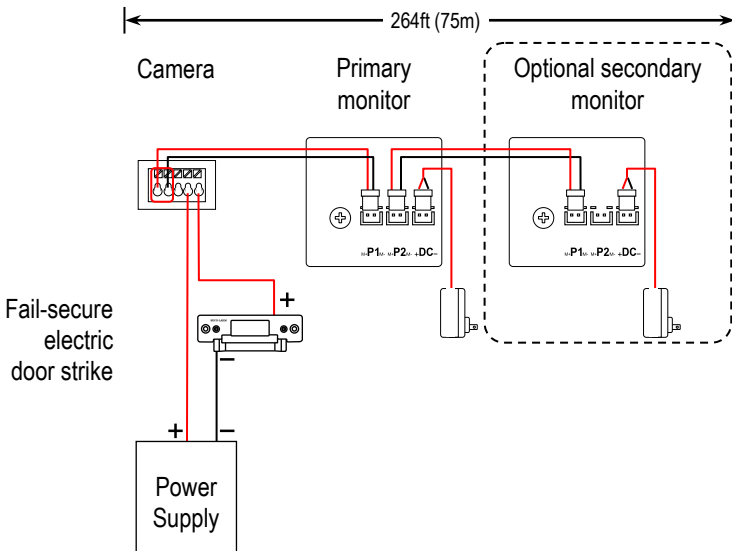

Troubleshooting:

The screen is blank.

- Check that the camera is powered up.
 - Check that the power supply's polarity is correct.
 - Check that the monitor is powered up.
 - Check that the video cable connecting the camera to the monitor is connected properly.
 - Check that the wiring distance does not exceed 246ft (75m)
-

The screen image is dim.

- Clean the lens using a soft, clean cloth.
 - Check that the light source is adequate
-

The screen image has poor color tone or flickers

- Adjust the monitor's color tone.
 - Adjust the monitor's brightness.
 - Change the position of the camera.
 - Check that the wiring distance does not exceed 246ft (75m)
-

The screen image is distorted.

- Change the position of the camera.
 - Check that the wiring distance does not exceed 246ft (75m)
-

The camera case is hot.

- Check that the correct power supply is in use (17VDC).
-

LEDs do not turn on.

- Check that the correct power supply is in use (17VDC).
 - Check that the wiring distance does not exceed 246ft (75m)
-

Lock button does not operate the relay

- Check that the correct power supply is in use (17VDC).
 - Check that the wiring distance does not exceed 246ft (75m)
-

IMPORTANT: Users and installers of this product are responsible for ensuring this product complies with all national, state, and local laws and statutes related to monitoring and recording audio and video signals. SECO-LARM will not be held responsible for the use of this product in violation of any current laws or statutes.

WARNING: Stop using the camera if you see a malfunction such as smoke or unusual heat, as it could cause fire or electric shock. Do not open the case of this device, as there are no field-serviceable components inside.

FCC COMPLIANCE STATEMENT: Information to the user: This equipment has been tested and found to comply with the limits for a class B digital device, pursuant to part 15 of the FCC rules. These limits are designed to provide reasonable protection against harmful interference in a residential installation. This equipment generates, uses and can radiate radio frequency energy and, if not installed and used in accordance with the instructions, may cause harmful interference to radio communications. However, there is no guarantee that interference will not occur in a particular installation. If this equipment does cause harmful interference to radio or television reception, which can be determined by turning the equipment off and on, the user is encouraged to try to correct the interference by one or more of the following measures:

- Reorient or relocate the receiving antenna.
 - Increase the separation between the equipment and receiver.
 - Connect the equipment into an outlet on a circuit different from that to which the receiver is connected.
 - Consult the dealer or an experienced radio/TV technician for help.
-

WARRANTY: This SECO-LARM product is warranted against defects in material and workmanship while used in normal service for a period of one (1) year from the date of sale to the original customer. SECO-LARM's obligation is limited to the repair or replacement of any defective part if the unit is returned, transportation prepaid, to SECO-LARM.

This Warranty is void if damage is caused by or attributed to acts of God, physical or electrical misuse or abuse, neglect, repair or alteration, improper or abnormal usage, or faulty installation, or if for any other reason SECO-LARM determines that such equipment is not operating properly as a result of causes other than defects in material and workmanship.

The sole obligation of SECO-LARM, and the purchaser's exclusive remedy, shall be limited to replacement or repair only, at SECO-LARM's option. In no event shall SECO-LARM be liable for any special, collateral, incidental, or consequential personal or property damages of any kind to the purchaser or anyone else.

NOTICE: The information and specifications printed in this manual are current at the time of publication. However, the SECO-LARM policy is one of continual development and improvement. For this reason, SECO-LARM reserves the right to change specifications without notice. SECO-LARM is also not responsible for misprints or typographical errors.

Copyright © 2013 SECO-LARM U.S.A., Inc. All rights reserved. This material may not be reproduced or copied, in whole or in part, without the written permission of SECO-LARM.

SECO-LARM® U.S.A., Inc.

16842 Millikan Avenue, Irvine, CA 92606

Tel: 800-662-0800 / 949-261-2999 Fax: 949-261-7326

Website: www.seco-larm.com

E-mail: sales@seco-larm.com



MIDP-234Q_1312.docx